



# Addressable Heat Detector AW-D102

## Product overview

Asenware AW-D102 heat detector is an intelligent rate of rise heat detector, which can be configured with Asenware AW-FP100 Series Addressable Fire Alarm Control Panel. Each point (devices) can be given specific ID, which allows the panel to continuously monitor specific detector location (point). It reduces the maintenance cost and makes it easier to maintain the system.



## Product Features

- Addressable-analog communication
- Rate-of-rise feature activates when ambient temperature increases at the rate of 7.1 °C/5S
- Low standby current
- Two-wire connection
- Two LEDs (RED), blinks in normal condition and becomes stationary during fire alarm condition.
- Remote test from Panel

## Spacing

Spacing of detector must be followed by standard EN 54 or NFPA 72. N FPA 72 suggests for low airflow application spacing of 9.1 m for ceiling height up to 3.15 m can be applicable. However, please follow the specific codes and local codes for specific applications.

---

### BOH Company Limited

Nat Sin Street #102, Kyee Myin Dine Township, Yangon 11101, Myanmar  
Dartu 2<sup>nd</sup> Street #170A, Ward 2, Hlaing Township, Yangon 11051, Myanmar  
[www.boh.com.mm](http://www.boh.com.mm), 01-7511610, 09768207455 [tto@boh.com.mm](mailto:tto@boh.com.mm)

# Technical Parameters

Model No.	AW-D102
D/C	1712
Operating Voltage Range	18V-28VDC
Alarm Current	≤3mA
Work Current	≤2.5mA
Temperature	-10°C to 50°C
Fix Temperature Range	57°C A2R
Rate of Rise Alarm	7.1°C/5S A2R
Standard Number Ref	EN 54-5:2000
Size	99.80 mm
Terminals Connection	No 6: Remote Indicator+
	No 3: Remote Indicator-
	No 2: Loop IN+ No 5: Loop IN-

## Addressable Heat Detector Installation

AW-D102 addressable detector use a separate base to simplify the installation and maintenance. For proper installation, terminal connections to be followed as shown below.

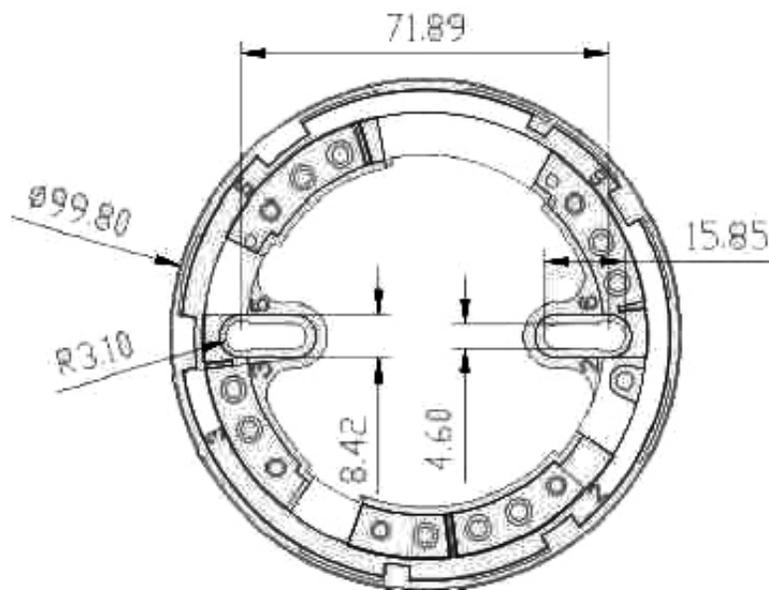

---

### BOH Company Limited

Nat Sin Street #102, Kyee Myin Dine Township, Yangon 11101, Myanmar

Dartu 2<sup>nd</sup> Street #170A, Ward 2, Hlaing Township, Yangon 11051, Myanmar

[www.boh.com.mm](http://www.boh.com.mm), 01-7511610, 09768207455 tto@boh.com.mm