



Addressable Fire Alarm Relay Module AW-D113

Product Overview

Asenware AW-D113 is an intelligent addressable relay module, which can be configured with Asenware AWFP100 Series Addressable Fire Alarm Control Panel. Each point (devices) can be given specific ID or individual address, which allows the panel to continuously monitor specific location (point). The module has two panel controlled LED indicator. AWD113 control modules provides the system with a drycontact output for activating a variety of auxiliary devices, such as fans, dampers, control equipment, etc.



Product Features

- Addressable-analog communication
- Two-wire connection
- Two LEDs one is Green, which blinks in normal condition and another one is Red which becomes steady during fire alarm condition.
- Remote test from Panel

Technical Parameters

Model No	AW-D113
Operating Voltage	18V-28V DC
Standby Current	≤ 3mA
Alarm Current	≤ 30mA
Relay Capacity	2A@ 24VDC & 1A@ 25VAC
Protection Level	IP 30
Temperature	-10°C~50°C

BOH Company Limited

Nat Sin Street #102, Kyee Myin Dine Township, Yangon 11101, Myanmar
Dartu 2nd Street #170A, Ward 2, Hlaing Township, Yangon 11051, Myanmar
www.boh.com.mm, 01-7511610, 09768207455 tto@boh.com.mm

Installation

- AW-D113 addressable monitor module must be installed as per the final drawings and wiring diagram.
- Set the address on the monitor module using programmer.
- Secure the module in the electrical box, supplied with the monitor module.

Wiring Connection

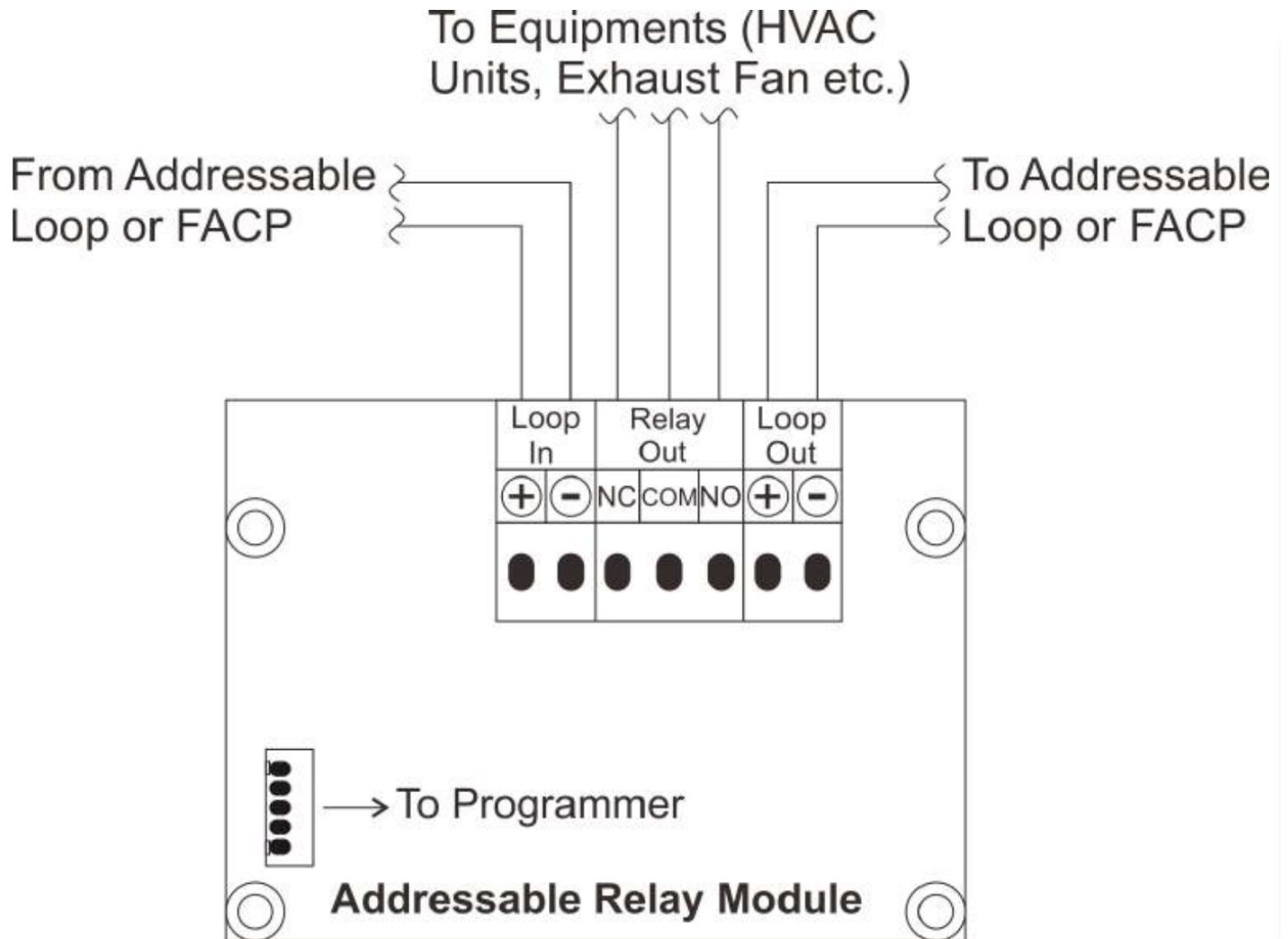

BOH Company Limited

Nat Sin Street #102, Kyee Myin Dine Township, Yangon 11101, Myanmar

Dartu 2nd Street #170A, Ward 2, Hlaing Township, Yangon 11051, Myanmar

www.boh.com.mm, 01-7511610, 09768207455 tto@boh.com.mm